

USER GUIDE

APOLLO KIT

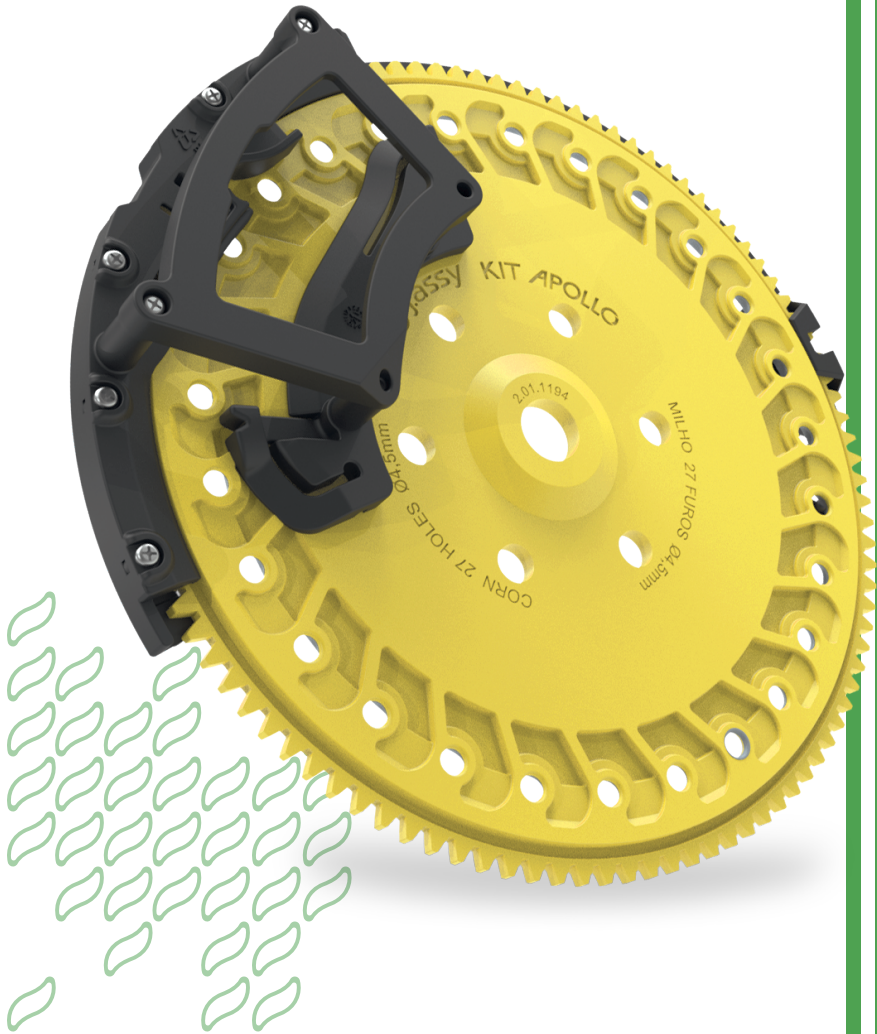

 **J.assy**



Apollo Kit

User Guide
v. 1.1

Contents

Introduction	4
Technical Specifications	5
Installation	6
Pre-Assembly Instructions	6
Assembly Instructions	7
Maintenance and Storage	9
Storage	9
Cleaning	9
Application of spray graphite	9
End of Life Signs	10
Troubleshooting	11
Excessive skips	11
Excessive doubles	11
High COV or SRI	12
Improper seed population	13
Motor stability, voltage and current	14
Disposal	15

Introduction

The **Apollo Kit** is a technology specifically developed and patented by J.Assy for use in pneumatic seed meters*.

Developed to offer a high level of planting performance, low maintenance and zero adjustments, the Apollo Kit is a compact and practical solution that replaces the seed metering disk, singulators, and ejector wheels, enabling a faster and more efficient planting operation.

**Compatible with vSet® 2 by Precision Planting® only. Trademarks not owned by J. Assy (including, but not limited to, vSet® and Precision Planting®) are the property of their respective owners and the use of such trademarks does not imply any affiliation between the trademark owners and J. Assy.*

Key Features of the Apollo Kit



 Soybean



 Soybean







 Canola

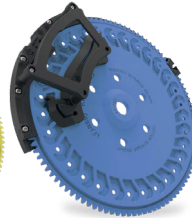





 Corn



 Cotton

-  Easy to assemble.
-  No adjustments required.
-  Compact and practical solution, a single part for each crop.
-  Efficient crop switching without the risk of losing components.
-  Excellent seed distribution and singulation.

Technical Specifications

	 CORN	 SOYBEAN				 COTTON	 CANOLA
Metering disk color	Yellow	Lilac	Dark purple		Blue	Red	
Number of holes	27	56	80		32	80	
Hole diameter	4.5 mm	4.2 mm	4.0 mm		3.2 mm	1.2 mm	
Baffle position	2	2	2		1 or 2	1	
Vacuum pressure	45-75 (mbar) 18-30 ("H ₂ O)	45-60 (mbar) 18-24 ("H ₂ O)	40-65 (mbar) 16-26 ("H ₂ O)	16-26 ("H ₂ O)	45-55 (mbar) 18-22 ("H ₂ O)	15-45 (mbar) 6-18 ("H ₂ O)	
Seed size	1000 – 3100 (kseeds/lb)	1700 - 5300 (kseeds/lb)	1700 - 5300 (kseeds/lb)		3600 – 6300 (kseeds/lb)	75 – 150 (kseeds/lb)	
Maximum seeding rate	38 (seeds/s)	120 (seeds/s)	160 (seeds/s)		50 (seeds/s)	110 (seeds/s)	
Expected singulation	>99%*	>99%*	>98%*		>99%*	>99%*	
Expected service life	1000h at 80 RPM or 3500 ac/row at 37.000 seeds/ac	1000h at 110 RPM or 2600 ac/row at 140.000 seeds/ac	1000h at 110 RPM or 2600 ac/row at 200.000 seeds/ac		1000h at 60 RPM or 3000 ac/row at 400.000 seeds/ac	1000 h at 80 RPM or 2600 ac/row at 200.000 seeds/ac	
Part number	2.02.0205	2.02.0206	2.02.0278		2.02.0264	2.02.0306	

*under optimized pressure conditions

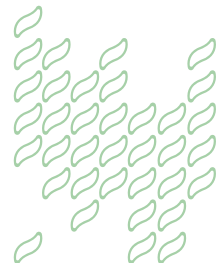

Installation

Pre-Assembly Instructions

The first step in installing the Apollo Kit is removing the springs holding the previous singulator installed inside the seed meter.

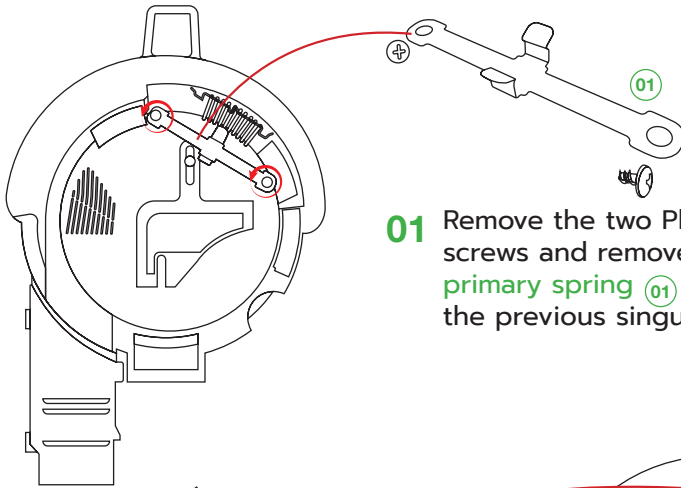

- 01** Remove the two Philips head screws and remove the **primary spring (01)** supporting the previous singulator.

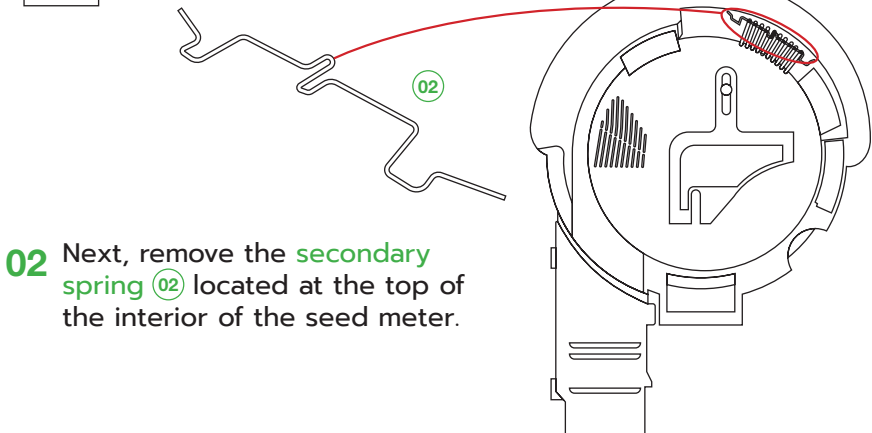

- 02** Next, remove the **secondary spring (02)** located at the top of the interior of the seed meter.

Once the old parts have been removed, the meter is ready for the installation of Apollo's kit.

**In the case of Canola crops, it is necessary to remove the additional part "Canola Ejector/Wiper Kit"*

Assembly Instructions

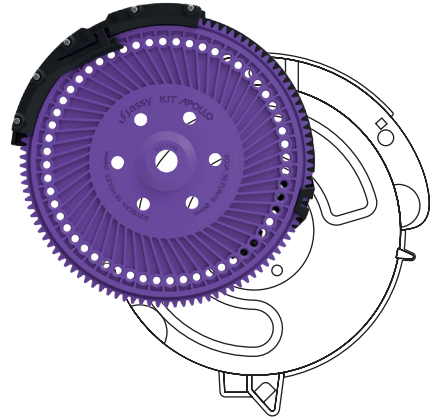
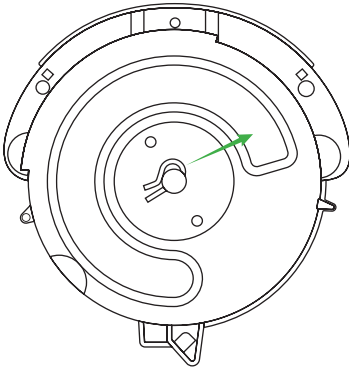

01 Remove the lock from the pin located on the meter's cover.

02 Insert the desired Kit Apollo, aligning the center hole with the cover's central pin.

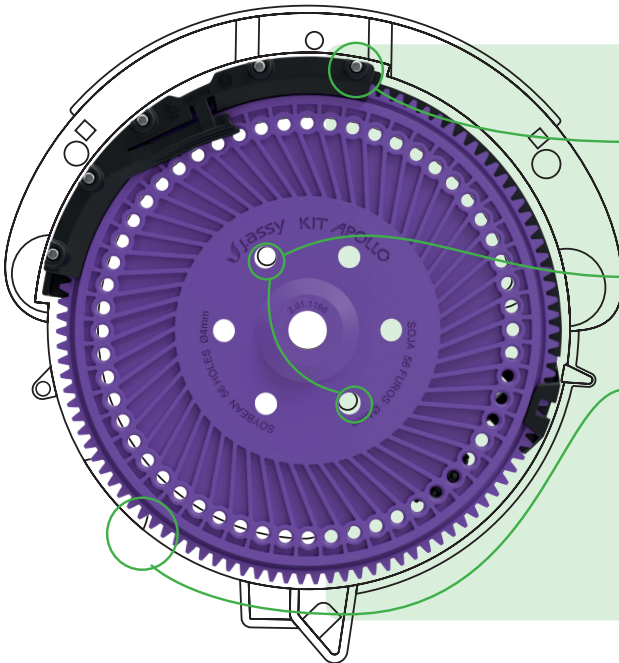

Important

- 01** The upper pad must be properly aligned with the recess located on the meter cover.
- 02** Align the two guide pins with any two of the metering disk's center holes.
- 03** Make sure the gear's teeth are aligned with the disk's teeth.
- 04** Make sure not to crush or fold the vacuum seal.

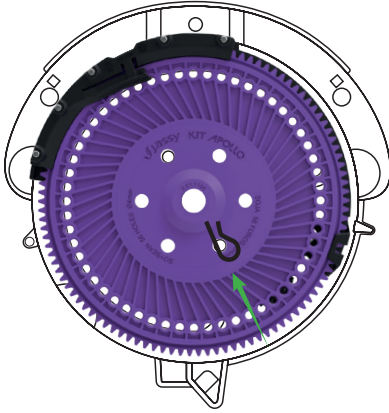

03 Place the locking pin back into position in order to fasten the kit to the unit.

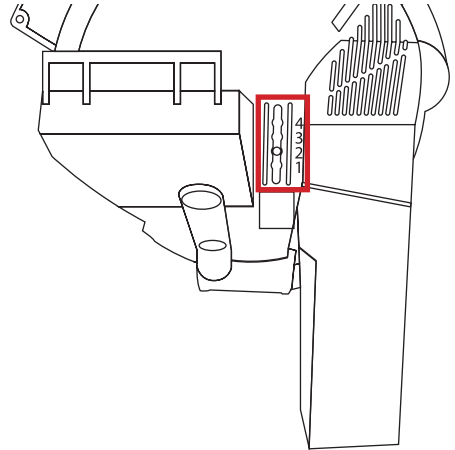

04 Adjust the baffle position according to the crop. [Check the table of technical specifications](#) for the desired crop.



Attention

- Do not force the disk teeth against the meter's drive gear.
- Check to make sure that the vacuum seal is not crumpled and is in good condition.

Helpful tip

To better align the pins with the center holes on the metering disk, turn the handle located behind the meter's cover.

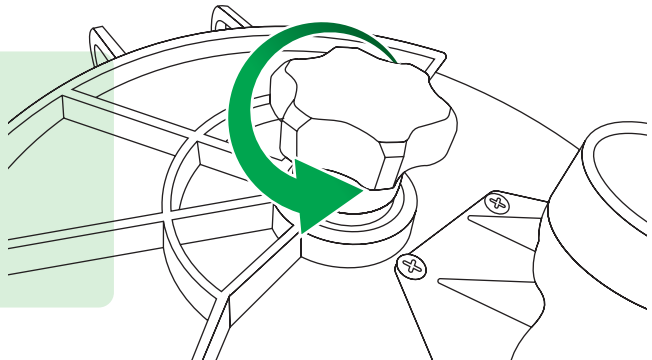

Maintenance and Storage

Storage

- When not in use, the Apollo Kit must be stored either in its original packaging or in another appropriate package in order to ensure that it is properly protected.
- Keep the Apollo Kit away from sunlight when it is stored for long periods of time, in order to prevent deterioration in the unit's parts and loss of color.
- Do not expose the Apollo Kit to temperatures above 203°F or below -22°F.

Cleaning



- Use a dry cloth and compressed air.
- Do not use harsh chemical cleaning products (Solupan, Metasil and others).
- It is recommended that the Apollo Kit be cleaned at the end of each planting season.

Application of graphite spray

Step by step instructions for applying graphite to the metering disk:

Place the **Apollo Kit** in a **horizontal position** and **apply lubricant spray** across the disk's surface.

Allow the disk to dry for at least 30 minutes (disassembling the kit is not required). See the image on the right.

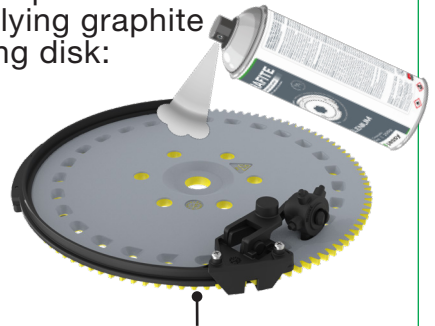

Place the Apollo Kit in a horizontal position.

End-of-Life Signs

The Apollo Kit will begin to show signs of wear after several years of use. **The kit is designed to maintain optimum performance even after the first signs of wear appear.**

It is recommended that the following criteria be used to determine whether it is time to replace a kit due to wear in its parts:



- **Upper pads:** When the upper pad is subjected to excessive wear, the kit's singulation is affected, resulting in an increased number of multiples or an excessive number of skips. It is recommended that the kit be replaced whenever a drop in singulation performance occurs.



- **Metering disk:** The contour of the disk holes may present signs of wear over time and affect the distribution of seeds in the soil. If seed distribution has been greatly impaired and the disk holes are visibly deformed, it is recommended that the kit be replaced.



- **Ejector wheel:** The ejector wheel's teeth must be capable of penetrating the disk holes in order to remove any debris and ensure the holes are kept clean. If any of the ejector wheel's teeth are worn to the point where they are no longer able to reach through the disk holes, it is recommended that the kit be replaced.

Troubleshooting

Excessive skips

Skips are characterized by a lack of seeds in the disk holes resulting in a low seed population. These issues can be reduced by taking the following measures:

- Check that the kit being used is appropriate for the crop being planted. Verify that the baffle position is adjusted correctly. For more information, see the section [‘Technical Specifications’ on page 5](#) of this manual.
- Make sure that the vacuum pressure is correctly set. If the skips (lack of seeds) persist, try to increase the vacuum pressure until the skips have been reduced as much as possible.
- Check that the seeds have been properly lubricated. It is recommended that dry powdered graphite, talc or a mixture of both be applied to the seeds and mixed in a uniform manner to ensure that seeds move easily within the seed meter.
- Check to make sure that there are no debris stuck inside the metering disk’s holes.
- Check the vacuum seal to make sure that it is in good condition and does not show signs of wear.
- Check the kits for signs of excessive wear. For more information, see the section [End-of-Life Signs on page 10](#) of this manual.

Excessive multiples

Multiples refer to the presence of two or more seeds in disk holes resulting in a high population. The amount of multiples in the Apollo Kit can be reduced by taking the following measures:

- Check that the kit being used is appropriate for the crop being planted. Verify that the baffle position is adjusted correctly. For more information, see the section [‘Technical Specifications’ on page 5](#) of this manual.

- Make sure that the vacuum pressure is correctly set. If multiples persist, decrease the vacuum pressure until the multiples have been reduced as much as possible.
- Check that the seeds have been properly lubricated. It is recommended that dry powdered graphite, talc or a mixture of both be applied to the seeds and mixed in a uniform manner to ensure that seeds move easily within the meter.
- Check the kits for signs of excessive wear. For more information see the section [End-of-Life Signs on page 10](#) of this manual.

High COV or SRI

If the spacing between seeds in the soil, which is measured by COV (Coefficient of Variation) or SRI (Seed Distribution Index), is not sufficient, we recommend that the following actions be taken:

- Check the meter's seed outlet and the seed tube. Debris inside the seed tube and poorly installed seed sensors can result in interference when guiding the seeds to the soil, which in turn affects the seed distribution.
- Check the meter's drive system. Make sure the system is in proper operating condition and well lubricated.
- Check for objects preventing the Apollo Kit from rotating continuously.
- Check that the seeds have been properly lubricated. It is recommended that dry powdered graphite, talc or a mixture of both be applied to the seeds and mixed in a uniform manner to ensure that seeds move easily within the meter. This will ensure that the seeds are released from the metering disk at the right time.
- Reduce speed to check if the problem is being caused by excessive vibration.
- If the seed tube includes a seed sensor, check to make sure that it

is properly installed. The sensor must not extend beyond the seed tube's inner wall.

- Check that the teeth on the metering disk's gear and pinion are in good condition. Replace parts with damaged teeth.
- Check the kits for signs of excessive wear. For more information see the section [End-of-Life Signs on page 10](#) of this manual.
- Check that the kit is correctly installed inside the meter.

Improper seed population

If the seed population in the soil is not at desired levels, the following steps can be taken:

- If the meter is driven by a hydraulic or electric motor, check that the number of holes in the disk is correctly set on the monitor controlling the motors.
- If the meter is driven by the planter's drive wheel, check to make sure that the gears being used are in line with the recommendations included in the seed distribution rate table.

Motor stability, voltage and current

If the electric motor driving the meter is having difficulty maintaining the correct speed, an alert for low stability may be triggered.

If the motor is not receiving the power required for operations, the monitor may also display a low voltage alert. We recommend that the following steps be taken in such cases:

- Check to make sure that settings for seed population, crop and number of disk holes are correct on the control monitor and that the electric motor's rotation speed does not exceed technical specifications.
- Make sure the power supply is properly sized for the planter that you are using. It is possible in such cases that a certain system element is consuming a large amount of energy, and there is not enough energy left to drive the meter's electric motors. If slowing down the tractor resolves stability issues, this is a sign that an element of the system is consuming an excessive amount of energy.
- Check that the teeth on the metering disk's gear and pinion are in good condition. Replace parts with damaged teeth.
- Check for any form of debris preventing the kit from rotating. If the disk is jamming, an excessive level of current may be required from the electric motor, triggering an alarm.
- Check that the graphite coating applied to the rear of the disk is in good condition and, if necessary, reapply the graphite spray.

Disposal

Equipment must be sent to your nearest J.Assy reseller partner, or to the OEM in cases involving a direct purchase, at the end of its service life. The equipment will then be properly disposed of by those responsible for this process.

Once you have read and implemented the guidelines contained in this manual, your Apollo Kit will be ready for planting.

IF YOU HAVE ANY QUESTIONS OR A POTENTIAL EQUIPMENT ISSUE, PLEASE CONTACT THE SALES REPRESENTATIVE FOR YOUR REGION, OR VISIT:

www.jassy.ag



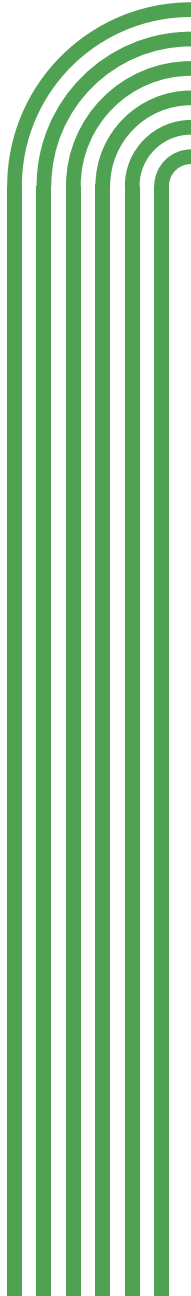
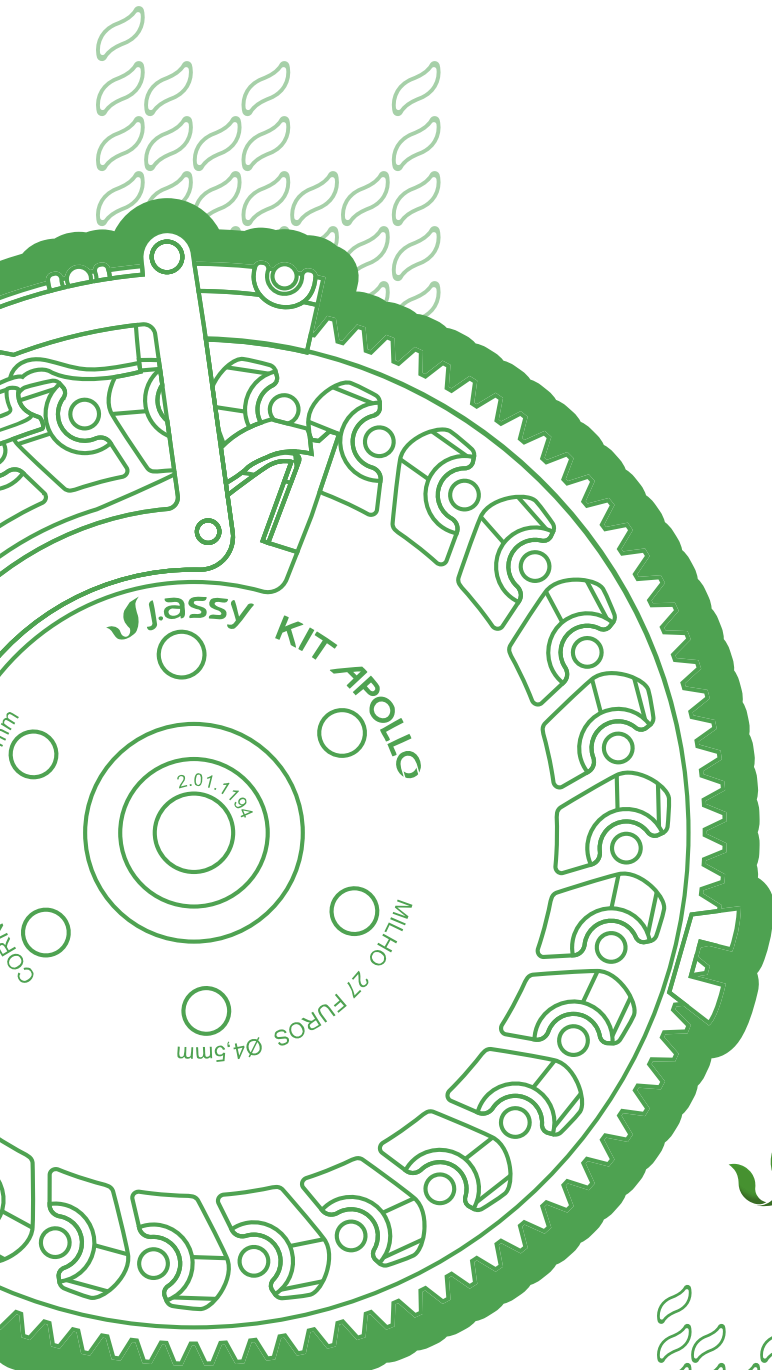

 **J.assy**

www.jassy.ag

